

FRENO Y EMBRAGUE DE PRENSA / *PRESS BRAKES AND CLUTCH*

TIPO MG / *TYPE MG*

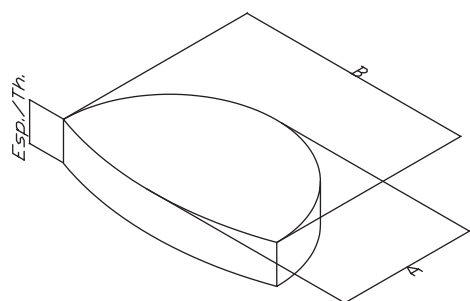

DESCRIPCIÓN / *DESCRIPTION*

MG A x B x Esp / *Th.*

CALIDADES / *QUALITY*

FAG/M NT-DV

→ MECANIZAMOS TODO TIPO DE PIEZA
SEGÚN PLANO O MUESTRA
*WE MACHINE ALL SORT OF PRESS BRAKES
ACCORDING TO SAMPLE / DRAWING*

REFERENCIA	PLANO	A	B	Espesor
<i>PART N°</i>	<i>DRAWING</i>	<i>A</i>	<i>B</i>	<i>Thickness</i>
I 6629 10 *	003-662	39	66	13,5
I 6425 10 *	004-264	60	99	30
I 6508 10 *	000-983	65	125	23,0
I 7426 10 *	000-984	74	144	34,0
I 7904 10 *	001-368	79	133	32,0
I 8055 10 *	002-976	80	135	30
I 8089 10 *	003-893	80	135	35
I 8131 10 *	000-983	81	136	23
I 8139 10 *	000-268	81	136	32
I 8139 11 *	000-839	81	136	32
I 8101 10 *	003-155	81	136	34
I 8108 10 *	003-390	81	136	35
I 8106 10 *	003-409	81	136	36
I 8911 10 *	000-666	88	152	32,0
I 8801 10 *	001-132	88	152	34
I 8826 10 *	001-539	88	152	35
I 8822 10 *	003-408	88	152	36
I 8838 10 *	003-455	88	152	40
I 9016 10 *	000-582	90	155	34
I 9008 10 *	000-582	90	155	34,0
I 9044 10 *	003-892	90	155	35
I 9013 10 *	000-360	90	155	36
I 10058 10 *	002-790	100	160	35
I 10049 10 *	002-349	100	175	36
I 10054 10 *	002-607	100	175	38
I 10035 10 *	000-361	100	175	40,0
I 11302 10 *	003-702	113	193	42
I 11503 10 *	001-202	115	197	38
I 11528 10 *	003-089	115	197	40
I 11538 10 *	003-703	115	197	42
I 11615 10 *	000-628	116	340	16,0
I 11836 10 *	002-327	118	200	57,1
I 11802 10 *	000-649	119	201	62,0
I 10230 10 *	000-111	121	204	62
I 12610 10 *	000-296	126	213	38
I 12637 10 *	000-999	126	221	44,0
I 12617 10 *	002-492	126	221	45
I 12706 10 *	001-982	127	218	40
I 12838 10 *	001-727	128	224	45
I 12921 10 *	002-048	129	220	38,0
I 12908 10 *	000-400	129	220	40
I 12926 10 *	000-579	129	224	40
I 13026 10 *	000-391	130	226	40
I 13039 10 *	000-614	130	230	45
I 13016 10 *	002-586	130	266	38
I 13125 10 *	003-035	131	225	10
I 13337 10 *	001-336	133	227	60,0
I 13434 10 *	002-986	134	228	8
I 13516 10 *	002-978	135	225	65
I 13531 10 *	000-273	135	229	57
I 13538 10 *	001-857	135	229	57,5

FRENO Y EMBRAGUE DE PRENSA / PRESS BRAKES AND CLUTCH

TIPO MG / TYPE MG

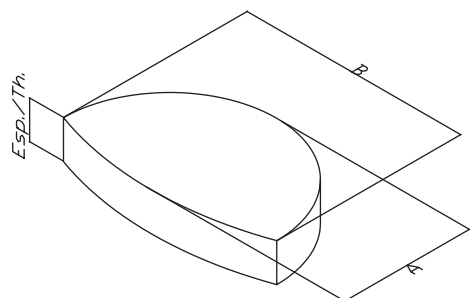

REFERENCIA	PLANO	A	B	Espesor
PART Nº	DRAWING	A	B	Thickness
I 13526 10 *	000-567	135	229	58
I 13624 10 *	000-497	136	238	8,0
I 13937 10 *	002-260	139	239	56,7
I 14019 10 *	003-861	140	240	60
I 14127 10 *	000-650	141	240	62,0
I 14125 10 *	001-970	141	244	45
I 14213 10 *	001-998	142	213	38
I 14321 10 *	000-552	143	240	62
I 14529 10 *	003-749	145	256	42
I 15735 10 *	003-065	157	264	63
I 15736 10 *	000-274	157	267	57
I 15831 10 *	002-977	158	265	57,5
I 15815 10 *	000-568	158	267	58,7
I 16040 10 *	001-782	160	282	46
I 16021 10 *	004-455	165	278	45

FRENO Y EMBRAGUE DE PRENSA / PRESS BRAKES AND CLUTCH

TIPO MR / TYPE MR

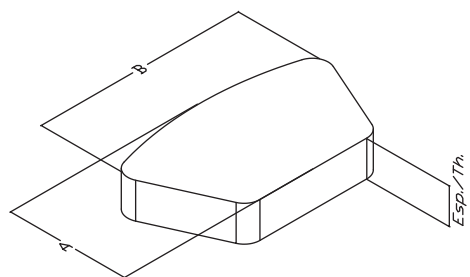

DESCRIPCIÓN / DESCRIPTION

MR A x B x Esp / Th.

CALIDADES / QUALITY

FAG/M NT-DV

→ MECANIZAMOS TODO TIPO DE PIEZA
SEGÚN PLANO O MUESTRA
WE MACHINE ALL SORT OF PRESS BRAKES
ACCORDING TO SAMPLE / DRAWING

REFERENCIA	PLANO	A	B	Espesor
PART Nº	DRAWING	A	B	Thickness
I 8113 10 *	001-886	81	138	34
I 8117 10 *	000-532	81	138	35
I 8132 10 *	003-853	81	138	30
I 10236 10 *	000-117	81	138	32
I 8338 10 *	001-324	83	144	12,0
I 8421 10 *	003-790	84	144	36
I 8513 10 *	003-758	85	140	10
I 8825 10 *	000-908	88	150	32,0
I 9012 10 *	002-842	90	155	32
I 9021 10 *	003-083	90	155	35
I 9041 10 *	003-626	90	155	34
I 9922 10 *	003-713	99	101	50
I 10069 10 *	003-300	100	160	35
I 10203 10 *	003-815	101	162	36
I 11431 10 *	000-873	114	197	40
I 19737 10 *	003-387	114	197	42
I 19740 10 *	000-873	114	197	40
I 12230 10 *	000-663	122	196	32,5
I 12517 10 *	000-741	125	180	50,0
I 22420 10 *	002-496	126	224	45
I 22634 10 *	002-491	126	224	45,0
I 22532 10 *	002-491	127	225	45
I 12840 10 *	003-770	128	223	43
I 12917 10 *	003-519	129	149	50
I 12927 10 *	003-869	129	206	40
I 12910 10 *	001-997	129	226	40,0
I 12918 10 *	002-779	129	226	45
I 10178 10 *	000-040	130	217	35

FRENO Y EMBRAGUE DE PRENSA / *PRESS BRAKES AND CLUTCH*

TIPO MR / *TYPE MR*

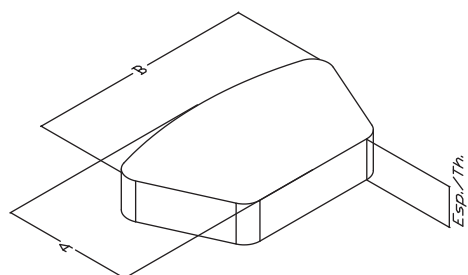

REFERENCIA	PLANO	A	B	Espesor
PART Nº	DRAWING	A	B	THICKNESS
I 13029 10 *	003-338	130	217	30
I 13040 10 *	000-647	130	217	32
I 13001 10 *	000-498	130	228	40
I 13030 10 *	000-613	130	228	45
I 13031 10 *	001-498	130	228	35
I 13001 10 *	000-498	130	228	40
I 13030 10 *	000-613	130	228	45
I 13031 10 *	001-498	130	228	35
I 14031 10 *	001-063	140	212	50,0
I 14309 10 *	002-661	143	240	45
I 14525 10 *	000-408	145	255	45,0
I 14531 10 *	002-827	145	260	46
I 15532 10 *	004-407	155	174	50
I 15936 10 *	003-154	159	279	50
I 16506 10 *	001-586	160	165	50
I 16045 10 *	003-427	160	282	50
I 21823 10 *	001-587	180	220	50,0
I 18506 10 *	001-087	185	302	50,0
I 18511 10 *	003-400	185	302	50
I 18815 10 *	001-112	188	307	6,0
I 18829 10 *	001-220	188	307	50
I 18834 10 *	001-098	188	307	42,0
I 20529 10 *	002-365	205	336	54
I 20614 10 *	002-826	205	336	50
I 29333 10 *	002-952	214	293	53
I 29513 10 *	003-559	214	295	52
I 29515 10 *	000-998	214	295	54,0
I 29535 10 *	000-800	214	295	50,0
I 10283 10 *	000-150	224	370	55
I 22533 10 *	003-026	225	370	55
I 22536 10 *	002-190	225	370	50,4
I 23539 10 *	003-613	235	350	54
I 23832 10 *	001-608	238	351	6,0
I 24239 10 *	002-819	242	264	44,5
I 26404 10 *	003-025	264	419	52
I 26410 10 *	000-801	264	419	50,0
I 26410 11 *	000-879	264	419	50,0
I 26424 10 *	001-157	264	419	54
I 26435 10 *	002-304	264	419	57

FRENO Y EMBRAGUE DE PRENSA / PRESS BRAKES AND CLUTCH

TIPO 8S / TYPE 8S

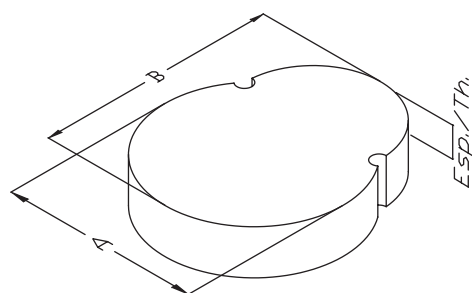

DESCRIPCIÓN / DESCRIPTION

8S A x B x Esp / Th.

CALIDADES / QUALITY

FAG/M NT-DV

→ MECANIZAMOS TODO TIPO DE PIEZA
SEGÚN PLANO O MUESTRA
WE MACHINE ALL SORT OF PRESS BRAKE
ACCORDING TO SAMPLE / DRAWING

REFERENCIA	PLANO	A	B	Espesor
PART N°	DRAWING	A	B	Thickness
I 886 10 *	003-888	34	68	17,5
I 868 10 *	002-778	35	70	17,5
I 845 10 *	001-814	58	69	35,0
I 819 10 *	000-795	69	139	30
I 814 10 *	000-770	69	139	35
I 815 10 *	000-771	70	85	45
I 821 10 *	000-815	70	85	34
I 869 10 *	002-895	70	85	40
I 803 10 *	000-253	70	85	42
I 878 10 *	003-520	70	85	42
I 840 10 *	001-646	70	85	42,0
I 861 10 *	002-430	70	85	44,0
I 871 10 *	002-925	70	85	45
I 864 10 *	002-581	70	85	46
I 860 10 *	002-401	70	101	38,0
I 872 10 *	002-991	70	102	38
I 825 10 *	000-826	75	127	38,5
I 810 10 *	000-618	80	150	30
I 816 10 *	000-773	80	150	30
I 880 10 *	003-623	90	108	42
I 867 10 *	002-720	100	120	42
I 885 10 *	003-828	100	120	45
I 879 10 *	003-605	100	120	50
I 848 10 *	001-880	105	128	34,0
I 877 10 *	003-478	105	128	38,5
I 800 10 *	000-097	113	136	50
I 844 10 *	001-802	115	137	45
I 805 10 *	000-270	115	137	46
I 808 10 *	000-455	115	137	50
I 855 10 *	002-145	115	138	40
I 851 10 *	001-883	120	140	36,0
I 881 10 *	003-685	125	150	40
I 843 10 *	001-722	125	150	44,5
I 834 10 *	001-265	127	152	57,1
I 826 10 *	000-904	135	162	45,0
I 809 10 *	000-474	135	200	45
I 822 11 *	001-374	146	178	38
I 804 10 *	000-383	146	178	38,5
I 858 10 *	000-821	146	178	38,5
I 823 10 *	000-822	146	178	38,8
I 817 10 *	000-778	146	178	45
I 859 10 *	002-383	146	178	47
I 831 10 *	001-062	146	178	50
I 854 10 *	001-927	146	178	50,3
I 806 10 *	000-419	146	178	38,5
I 811 10 *	000-653	146	178	38,5
I 812 10 *	000-679	146	178	39
I 807 10 *	000-420	146	178	42
I 887 10 *	003-905	146	178	42,5
I 849 10 *	001-881	146	178	45,0
I 841 10 *	001-648	146	178	48,0

FRENO Y EMBRAGUE DE PRENSA / *PRESS BRAKE AND CLUTCH*

TIPO 8S / *TYPE 8S*

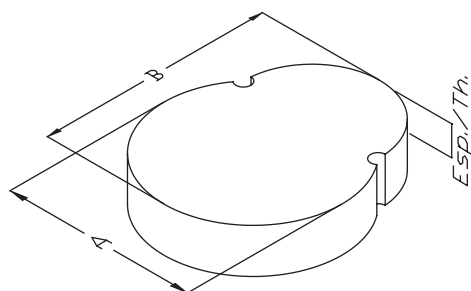

REFERENCIA	PLANO	A	B	Espesor
<i>PART Nº</i>	<i>DRAWING</i>	<i>A</i>	<i>B</i>	<i>Thickness</i>
I 839 10 *	001-465	146	178	48,1
I 833 10 *	001-155	146	178	54
I 847 10 *	001-858	146	178	57,5
I 801 10 *	000-113	146	178	60
I 884 10 *	003-761	147	178	38,5
I 802 10 *	000-176	151	271	55
I 846 10 *	001-825	170	205	57,0
I 873 10 *	003-066	170	290	65
I 876 10 *	003-466	172	193	64
I 835 10 *	001-266	177	218	57,1
I 818 10 *	000-784	178	219	57,1
I 836 10 *	001-267	202	247	63,5
I 820 10 *	000-797	204	248	57,1
I 856 10 *	002-226	231	409	64,0

FRENO Y EMBRAGUE DE PRENSA / *PRESS BRAKES AND CLUTCH*

TIPO PJ / *TYPE PJ*

18

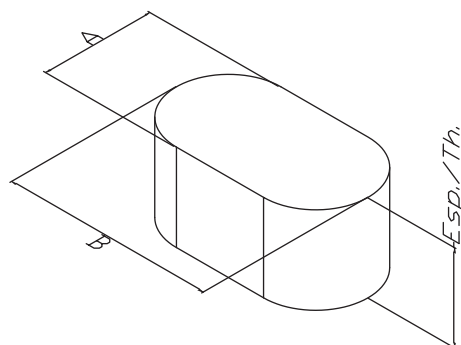

DESCRIPCIÓN / *DESCRIPTION*

PJ A x B x Esp / *Th.*

CALIDADES / *QUALITY*

FAG/M NT-DV

→ MECANIZAMOS TODO TIPO DE PIEZA
SEGÚN PLANO O MUESTRA
*WE MACHINE ALL SORT OF PRESS BRAKE
ACCORDING TO SAMPLE / DRAWING*

REFERENCIA	PLANO	A	B	Espesor
<i>PART Nº</i>	<i>DRAWING</i>	<i>A</i>	<i>B</i>	<i>Thickness</i>
I 1826 10 *	001-677	18	33	16,0
I 2036 10 *	003-842	20	40	12
I 2420 10 *	003-651	24	54	21
I 2417 10 *	002-835	24	55	25
I 2522 10 *	002-911	25	54	28
I 2534 10 *	002-333	25	54	27
I 2537 10 *	001-525	25	54	26
I 5426 10 *	000-703	25	54	25
I 5509 10 *	000-664	25	55	25
I 3511 10 *	004-678	35	85	30
I 3930 10 *	001-675	39	51	10,0
I 3924 10 *	003-652	39	79	28,5
I 10316 10 *	000-562	39	103	32
I 10437 10 *	002-261	40	105	40
I 4045 10 *	001-526	40	52	9,9
I 4037 10 *	000-829	40	77	35
I 4069 10 *	002-811	40	79	32
I 4002 10 *	000-559	40	80	35
I 4040 10 *	001-078	40	80	40
I 4091 10 *	003-611	40	95	32
I 4085 10 *	003-417	40	101	50
I 4028 10 *	000-248	40	104	30
I 10401 10 *	003-167	40	104	45
I 4065 10 *	002-582	40	105	54
I 4081 10 *	003-291	40	105	38,5
I 4086 10 *	003-426	40	105	35
I 10504 10 *	002-658	40	105	45
I 10518 10 *	001-475	40	105	41
I 10519 10 *	002-886	40	105	39

FRENO Y EMBRAGUE DE PRENSA / PRESS BRAKES AND CLUTCH

TIPO PJ / TYPE PJ

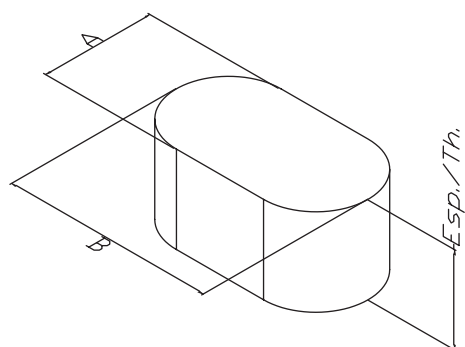

REFERENCIA	PLANO	A	B	Espesor
PART Nº	DRAWING	A	B	Thickness
I 10519 10 *	002-886	40	105	39
I 10529 10 *	000-342	40	105	42
I 10535 10 *	003-493	40	105	50
I 10536 10 *	002-237	40	105	40
I 13510 10 *	000-201	40	105	42
I 4208 10 *	001-964	42	85	32,0
I 5077 10 *	002-583	50	124	54
I 5042 10 *	001-257	50	125	36
I 5229 10 *	001-351	52	62	32,0
I 5236 10 *	000-792	52	62	30
I 6210 10 *	002-142	52	62	33
I 7405 10 *	000-366	56	74	24
I 5934 10 *	003-550	59	74	50
I 10151 10 *	000-053	59	74	30
I 10152 10 *	000-054	59	74	35
I 6082 10 *	003-292	60	72	25
I 10278 10 *	000-144	60	74	30
I 6007 10 *	000-670	60	75	22,0
I 6011 10 *	000-469	60	75	26
I 6028 10 *	000-841	60	75	30
I 6064 10 *	002-369	60	75	20,0
I 6068 10 *	002-568	60	75	45
I 6095 10 *	003-824	60	75	24
I 10237 10 *	000-118	60	75	25
I 10237 11 *	000-681	60	75	25
I 10237 12 *	002-569	60	75	25
I 22825 10 *	000-181	60	75	27
I 6005 10 *	000-727	60	110	47
I 6013 10 *	001-050	60	110	32,0
I 6018 10 *	001-048	60	110	51
I 6030 10 *	000-243	60	110	50
I 6030 11 *	001-380	60	110	50
I 6034 10 *	000-702	60	110	45
I 6046 10 *	001-550	60	110	4,0
I 6056 10 *	001-996	60	110	48,0
I 6058 10 *	002-167	60	110	55,0
I 6081 10 *	003-219	60	110	43
I 6088 10 *	003-448	60	110	40
I 11020 10 *	002-713	60	110	36
I 11043 10 *	002-984	60	110	50
I 11043 11 *	001-380	60	110	50
I 6035 10 *	000-719	61	76	24
I 6104 10 *	001-370	61	75	25,0
I 6107 10 *	000-349	61	78	26
I 6436 10 *	001-424	64	90	30
I 6516 10 *	000-206	65	90	35
I 24421 10 *	000-170	65	90	30
I 6513 10 *	002-781	65	91	30
I 6529 10 *	001-153	65	91	10
I 6530 10 *	000-424	65	91	32
I 7003 10 *	000-934	70	175	50

FRENO Y EMBRAGUE DE PRENSA / *PRESS BRAKE AND CLUTCH*

TIPO PJ / *TYPE PJ*

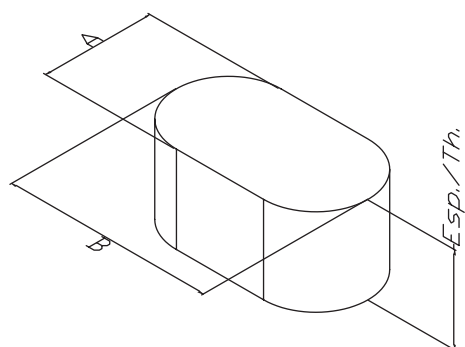

REFERENCIA	PLANO	A	B	Espesor
<i>PART N°</i>	<i>DRAWING</i>	<i>A</i>	<i>B</i>	<i>Thickness</i>
I 7005 10 *	001-247	70	175	55
I 7009 10 *	002-080	70	175	5
I 7016 10 *	002-074	70	175	53
I 7035 10 *	000-870	70	175	45
I 7035 11 *	002-676	70	175	45
I 10150 1 *	000-052	70	175	50
I 10150 3 *	001-328	70	175	50
I 10150 4 *	002-099	70	175	50
I 10150 5 *	003-537	70	175	50
I 10150 6 *	003-598	70	175	50
I 17512 10 *	002-910	70	175	49
I 17524 10 *	000-794	70	175	56
I 17534 10 *	001-093	70	175	7
I 7045 10 *	002-855	70	180	50
I 7914 10 *	000-204	79	110	33
I 7932 10 *	001-342	80	112	37
I 8017 10 *	002-043	80	110	35
I 8004 10 *	001-360	80	112	33,0
I 8010 10 *	000-423	80	112	37
I 8029 10 *	000-863	80	112	39
I 8034 10 *	000-334	80	112	41
I 8035 10 *	000-367	80	112	35
I 8041 10 *	001-154	80	112	10
I 14096 10 *	000-169	80	112	40
I 8045 10 *	002-377	80	200	20,0
I 10932 10 *	003-811	90	109	26,3
I 11023 10 *	002-974	90	110	32
I 9050 10 *	004-527	90	170	45
I 9006 10 *	000-887	90	240	55
I 9006 11 *	003-165	90	240	55
I 9403 10 *	000-868	94	200	35
I 9632 10 *	000-368	96	135	38
I 26812 10 *	000-577	108	268	10
I 14737 10 *	004-210	147	198	50

FRENO Y EMBRAGUE DE PRENSA / PRESS BRAKES AND CLUTCH

TIPO DC / TYPE DC

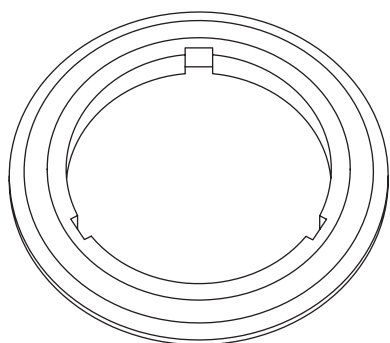

DESCRIPCIÓN / DESCRIPTION

DC \varnothing Int x \varnothing Ext x Esp
DC \varnothing Out x \varnothing In x Th

CALIDADES / QUALITY

MM

REFERENCIA	PLANO	\varnothing EXT	\varnothing INT	Espesor
PART N°	DRAWING	\varnothing OUT	\varnothing IN	Thickness
I 10216 10 40	000-099	150	90	18/20
I 17007 10 40	001-430	170	105	18/20
I 18028 10 40	000-397	180	110	21/23
I 19033 10 40	003-726	190	110	21/23
I 21048 10 40	000-239	210	125	20,5/22,5
I 22026 10 40	003-617	220	125	20,5/22,5
I 32528 10 40	002-946	325	200	24/26
I 10267 10 40	000-138	330	200	24/26
I 33527 10 40	002-464	335	200	24/26

TIPO PA / TYPE PA

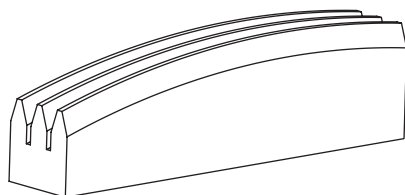

DESCRIPCIÓN / DESCRIPTION

PA \varnothing Int x \varnothing Ext x Esp
PA \varnothing Out x \varnothing In x Th

CALIDADES / QUALITY

MM

REFERENCIA	PLANO	\varnothing LONG	\varnothing ALT	Espesor
PART N°	DRAWING	\varnothing LONG	\varnothing HIGH	Thickness
I 10217 10 40	000-100	192	55	56
I 21503 10 40	000-758	215	54	55
I 23922 10 40	000-396	239	48	65
I 10218 10 40	000-104	364	73	86
I 46215 10 40	000-336	462	96	100

21

TIPO MSE / TYPE MSE

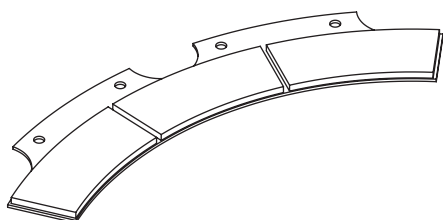

CALIDADES / QUALITY

FAG/M

REFERENCIA	PLANO	\varnothing EXT	Ancho	Espesor
PART N°	DRAWING	\varnothing OUT	Width	Thickness
M 3007 11 25	002-102	302	38	4,3
M 3723 10 25	002-103	376	32	5,8
M 4630 10 25	000-519	463	38	5,8
M 4907 11 25	000-855	495	40	6,9
M 5918 10 25	000-662	590	50	7,9
M 6638 11 25	001-091	666	103	8,5